



Lochinvar®

HIGH EFFICIENCY BOILERS & WATER HEATERS

COPPER-FIN® COMMERCIAL GAS BOILER

Submittal Sheet

CB-Sub-13

COPPER-FIN GAS BOILER (MODELS CB 0497-2067)

Job Name: _____ Model No. _____

Location: _____ Type Gas: _____

Engineer: _____ BTU/hr INPUT: _____ BTU/hr OUTPUT: _____

Agent/Wholesaler: _____ Equipment Tag(s): _____

Contractor: _____

NOTES:

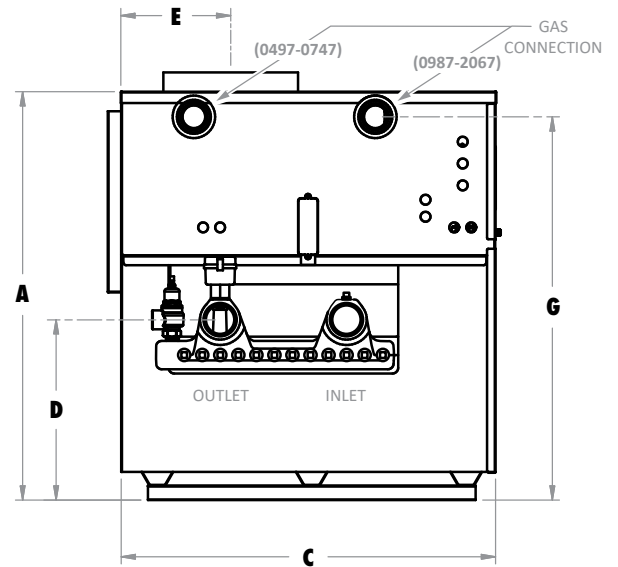
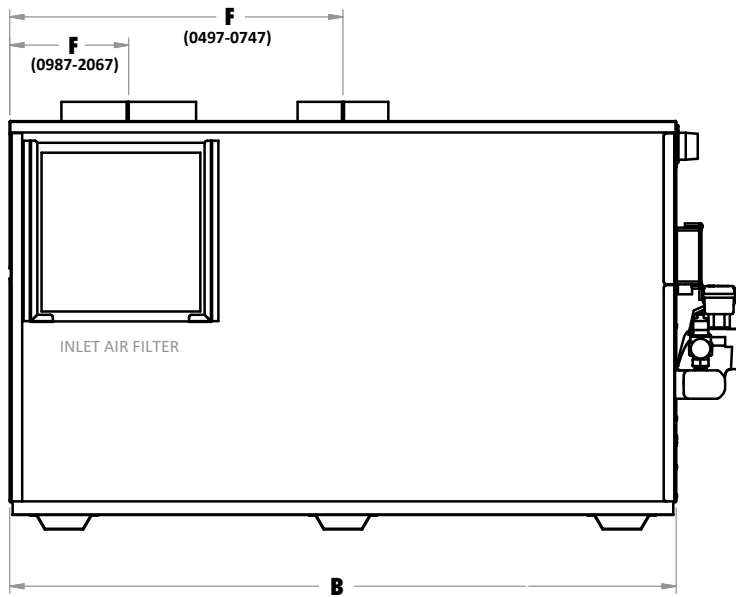

Copper-Fin Heating Boiler					Dimensions & Specifications										
Model No.	Input Max MBH	Thermal Eff.	Heat Cap. MBH	Net AHRI Rating MBH	A	B	C	D	E	F	G	Gas Conn.	Vent Size	Ship Wt.	
CBN0497	495	81%	401	349	31-1/2"	45-1/4"	22-1/4"	12-1/2"	9-1/2"	22-3/4"	29-1/2"	1-1/4"	6"	440	
CBN0647	645	81%	522	454	31-1/2"	56-3/4"	22-1/4"	12-1/2"	9-1/2"	28-1/2"	29-1/2"	1-1/4"	8"	510	
CBN0747	745	81%	603	524	31-1/2"	64"	22-1/4"	12-1/2"	9-1/2"	32"	29-1/2"	1-1/4"	8"	550	
CBN0987	985	81%	798	694	36"	48-1/4"	33-1/2"	15-3/4"	8-1/2"	8-1/2"	33-3/4"	2"	10"	845	
CBN1257	1255	81%	1,017	884	36"	58-1/2"	33-1/2"	15-3/4"	9-1/2"	10-1/2"	33-3/4"	2"	12"	905	
CBN1437	1435	81%	1,162	1,010	36"	68-3/4"	33-1/2"	15-3/4"	10-1/2"	10-1/2"	33-3/4"	2"	12"	1050	
CBN1797	1795	81%	1,454	1,264	36"	82-1/4"	33-1/2"	15-3/4"	11"	11"	33-3/4"	2"	14"	1193	
CBN2067	2065	81%	1,673	1,455	36"	92-1/2"	33-1/2"	15-3/4"	11"	11"	33-3/4"	2"	14"	1350	

Notes: Change 'N' to 'L' for LP gas models.
No deration on LP models.
Performance data based on manufacturer test results.

Water connections for models CB 0497-747 are 2" NPT on 6-1/2" centers.
Water connections for models CB 0987-2067 are 2-1/2" NPT on 11-1/4" centers.
Information is subject to change without notice. Dimensions shown are approximate and should not be used for construction purposes.

Copper-Fin[®]

Refined Copper-Fin technology over 50 years to include advanced fan-assisted combustion, hot surface ignition, a unique gasketless copper finned tube heat exchanger and highly efficient insulating materials.



Standard Features

- 81% Thermal Efficiency
- Electronic Temperature Control
- Fan Assisted Combustion
- Sealed Combustion Chamber
- Stainless Steel Burners
- Low NOx Operation - Exceeds the most stringent air quality requirements
- ASME Copper Finned Tube Heat Exchanger
- 160 psi Working Pressure
- Gasketless Heat Exchanger Design
- High Voltage Terminal Strip 120V/1PH/60Hz
- Pump Relay w/Delay
- Down Stream Test Valve
- Referenced Gas Valves
- Loch-Heat Ceramic Tile Combustion Chamber
- Hot Surface Ignition
- Adjustable High Limit w/Manual Reset
- 50 psi ASME Relief Valve
- Temperature & Pressure Gauge
- Flow Switch
- 24 Volt Control System
- BMS Terminal Strip
- Combustion Air Filter
- Freeze Protection
- 10 Year Limited Warranty on Heat Exchanger (See warranty for details)

Optional Equipment

- Alarm on Any Failure
- Contacts on any Failure
- Contacts for Air Louvers
- Cupro-Nickel Heat Exchanger
- High & Low Gas Pressure Switch w/Manual Reset
- Outdoor Reset Control
- Manual Reset Low Water Cut-Off w/test
- Stack Frame
- MP2 Sequencer
- 30 psi ASME Relief Valve
- 75 psi ASME Relief Valve
- 100 psi ASME Relief Valve
- 125 psi ASME Relief Valve
- 150 psi ASME Relief Valve

Venting Options

- Outdoor Vent Cap

Model No.	Fans	Controls	Approx. Total Amps
497	3.6	3.6	7.2
647	3.6	3.6	7.2
747	3.6	3.6	7.2
987	3.4	4.6	8.0
1257	3.4	4.6	8.0
1437	3.8	4.6	8.4
1797	3.8	4.6	8.4
2067	3.8	4.6	8.4

Available Firing Systems

- M9** Hot Surface Ignition with Electronic Supervision (Standard)
- M13** GE GAP/FM/CSD1
- M7** California Code

Registered under U.S. Patent # 5,989,020



Lochinvar, LLC
300 Maddox Simpson Parkway
Lebanon, Tennessee 37090
P: 615.889.8900 / F: 615.547.1000
Lochinvar.com

